

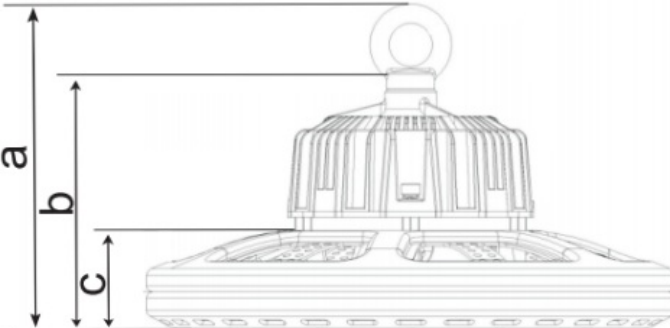

UFO High Bay

	<p>PRODUCT DESCRIPTION</p> <p>The UFO High Bay fixture features an innovative anti-glare design that reduces glare while enhancing lighting performance and distribution. Its versatile design allows for multiple light distribution angles, making it suitable for a wide range of commercial and industrial applications.</p>
	<p>ACCESSORIES</p> <p>Battery Backup Unit </p> <p>Motion Sensor </p> <p>   </p>

Dimensions

	
<p>100W - a: 171 b: 126 c: 52 d: 278 150W - a: 178 b: 133 c: 60 d: 328 200W - a: 196 b: 151 c: 75 d: 388 240W - a: 196 b: 151 c: 75 d: 388</p>	<p>All dimensions in millimeters</p>

Specifications

Part Number	Input Power	Input Voltage	Efficiency	CCT Selectable	Light Distribution	CRI	Certificates	Warranty
JH-UHB100W-82F	100W	100-277VAC	135Lm/W	3k/4k/5k	60° 90° 120°	70+	ETL	5 Years
JH-UHB150W-82F	150W	100-277VAC	135Lm/W	3k/4k/5k	60° 90° 120°	70+	ETL	5 Years
JH-UHB200W-82F	200W	100-277VAC	135Lm/W	3k/4k/5k	60° 90° 120°	70+	ETL	5 Years
JH-UHB240W-82F	240W	100-277VAC	135Lm/W	27k/40k/50k	60° 90° 120°	70+	ETL	5 Years